

RIGHT HAND
MANO DERECHA
MAIN DROITE

FULL SIZE TEMPLATES

120° TEMPLATE

(NHO)
REGULAR,
RÉGULIER

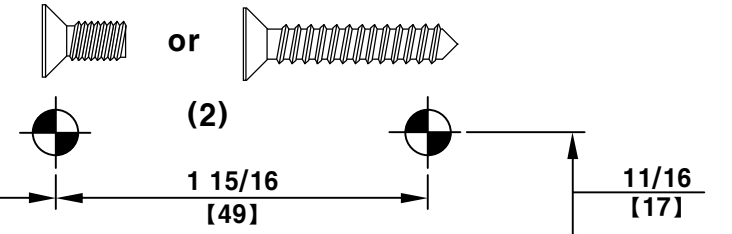

10 13/16
[275]

11/16
[17]

TOP EDGE OF DOOR

ALIGN LINE WITH BOTTOM OF FRAME FACE.
ALINEE CON LA PARTE BAJA DE LA CARA DEL MARCO.
ALIGNER CETTE LIGNE SUR LE BAS DE LA FACE DU CADRE.

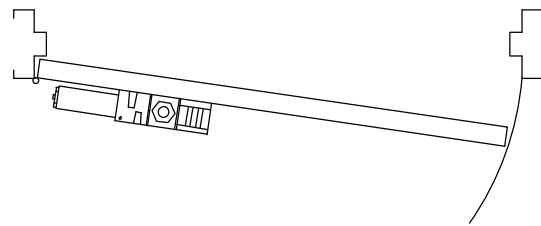

ALIGN WITH CENTER LINE OF HINGE.
ALINEE CON EL EJE DE LA BISAGRA.
ALIGNER SUR LE CENTRE DU PIVOT DE LA CHARNIÈRE.

1 1/4
[57]

(4)

or

6 1/4
[159]

1
[25]

3
[76]

1
[25]

METAL . 7/32" & 1/4-20 TAP, FOR WOOD 5/32". (FOR SEX NUTS USE 3/8")
CANILLA DE METAL 7/32" & 1/4-20, PARA MADERA 5/32". (PARA USO DE TUERCAS DE 3/8")
MÉTAL 7/32" & 1/4-20, bois 5/32". (ÉCROUS M-F, PERCER 3/8")

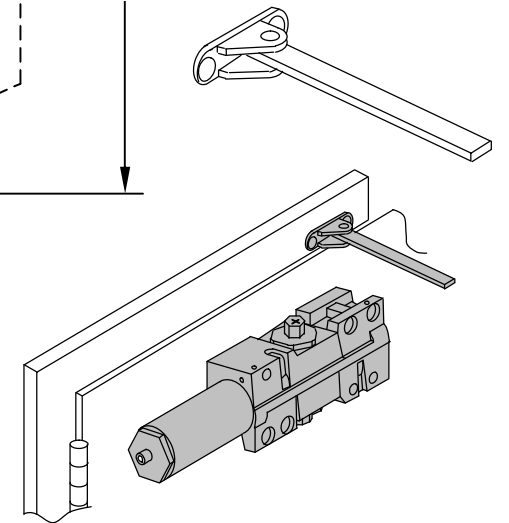

TEAR ALONG DOTTED LINE

TIRE DE LA LINEA PUNTEADA

DÉTACHER SUR LA LIGNE POINTILLÉE

**RIGHT HAND
MANO DERECHA
MAIN DROITE**
120° TEMPLATE

METAL . 7/32" & 1/4-20 TAP, FOR WOOD 5/32". (FOR SEX NUTS USE 3/8")
 CANILLA DE METAL 7/32" & 1/4-20, PARA MADERA 5/32". (PARA USO DE TUERCAS DE 3/8")
 MÉTAL 7/32" & 1/4-20, bois 5/32". (ÉCROUS M-F, PERCER 3/8")

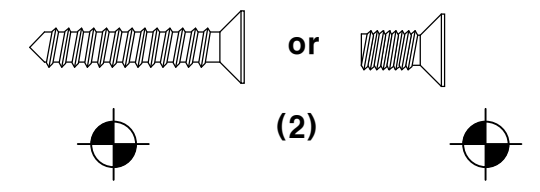
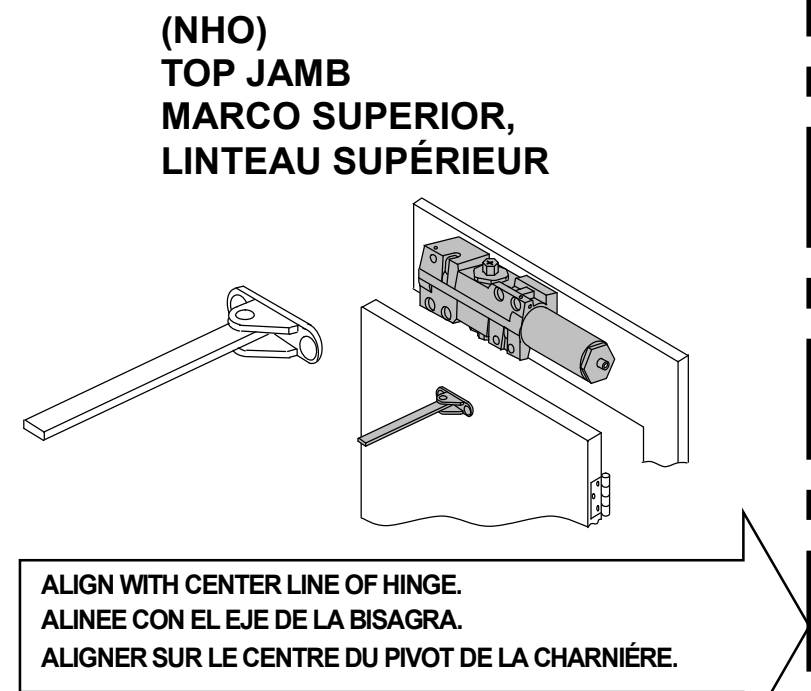
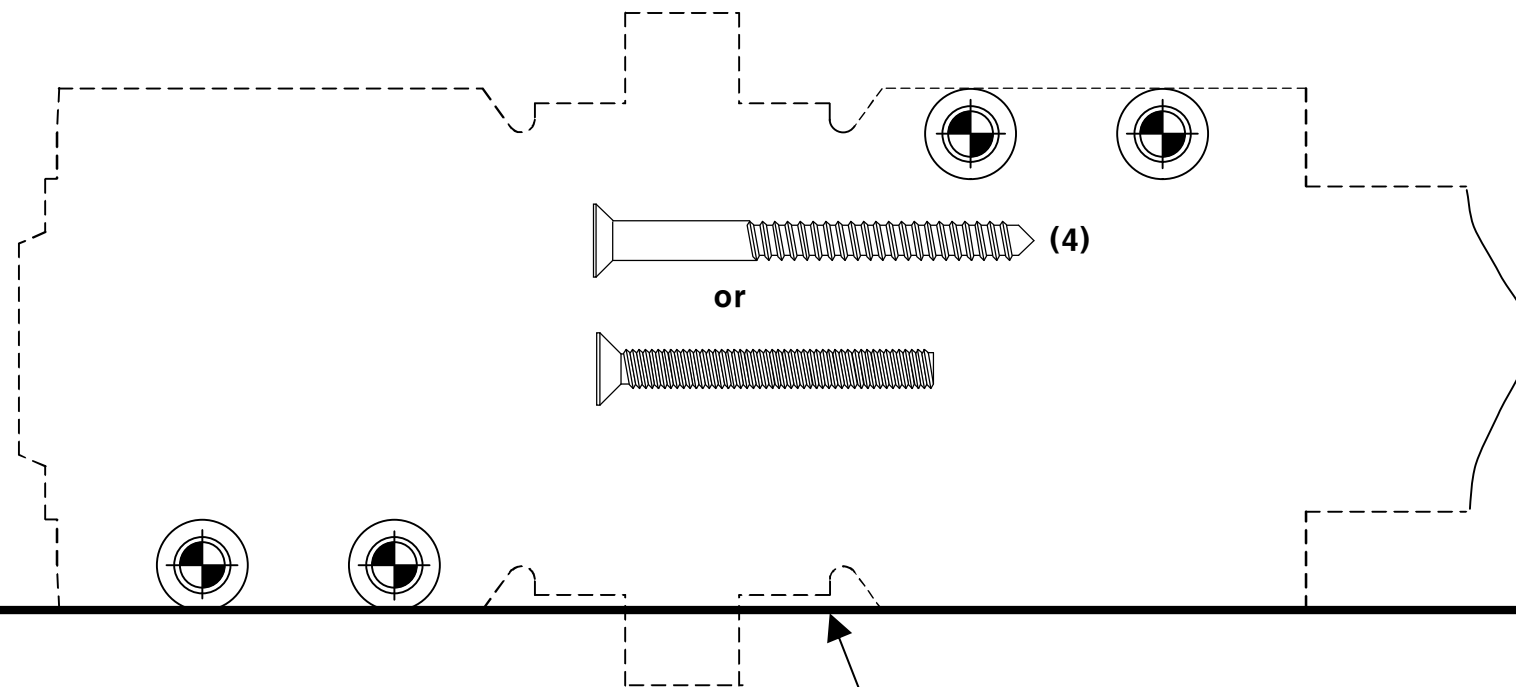
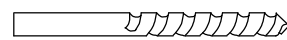

ALIGN LINE WITH BOTTOM OF FRAME FACE.
 ALINEE CON LA PARTE BAJA DE LA CARA DEL MARCO.
 ALIGNER CETTE LIGNE SUR LE BAS DE LA FACE DU CADRE.

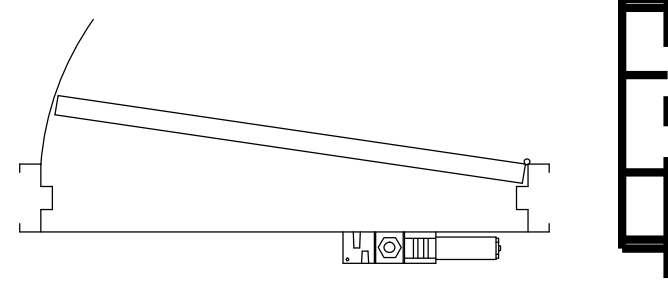

TEAR ALONG DOTTED LINE

TIRE DE LA LINEA PUNTEADA

DÉTACHER SUR LA LIGNE POINTILLÉE

**RIGHT HAND
MANO DERECHA
MAIN DROITE
180° TEMPLATE**

FOLD AND ALIGN LINE WITH BOTTOM OF STOP.
DOBLE Y ALINEE CON LA PARTE BAJA DEL TOPE.
PLIER ALIGNER CETTE LIGNE SUR LE BAS DE ARRÊT.

METAL . 7/32" & 1/4-20 TAP, FOR WOOD 5/32", (FOR SEX NUTS USE 3/8")
CANILLA DE METAL 7/32" & 1/4-20, PARA MADERA 5/32", (PARA USO DE
TUERCAS DE 3/8")
MÉTAL 7/32" & 1/4-20, bois 5/32", (ÉCROUS M-F, PERCER 3/8")

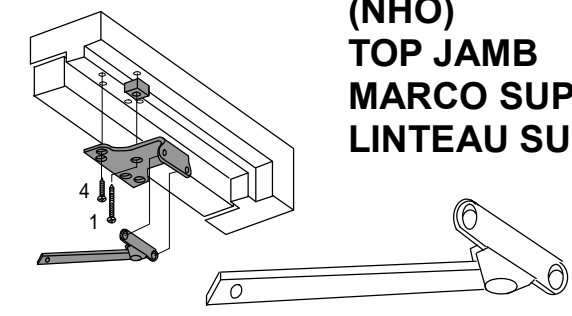
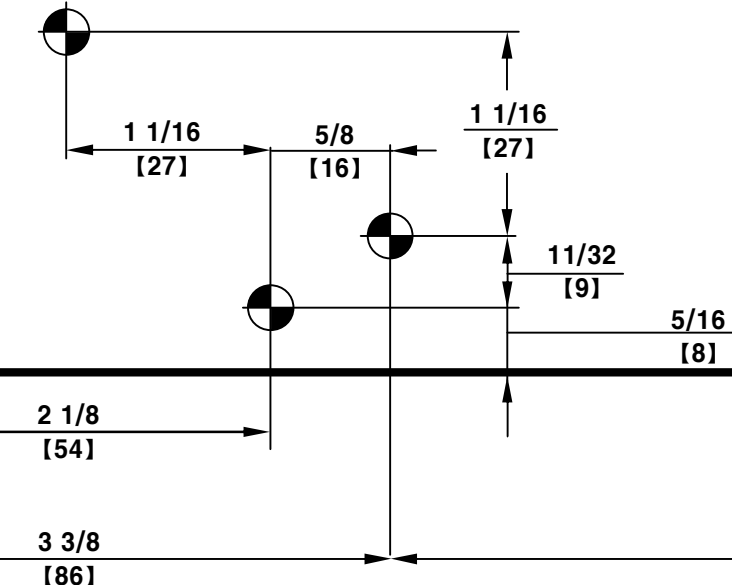
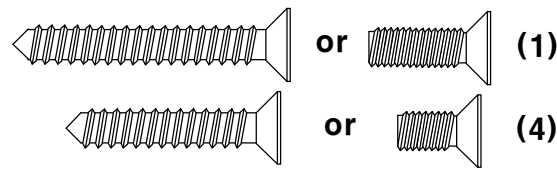

**(NHO)
TOP JAMB
MARCO SUPERIOR,
LINTEAU SUPÉRIEUR**

2 5/16 [59]

1 [25]

3 [76]

1 [25]

6 3/16 [157]

6 1/2 [165]

ALIGN WITH CENTER LINE OF HINGE.
ALINEE CON EL EJE DE LA BISAGRA.
ALIGNER SUR LE CENTRE DU PIVOT DE LA CHARNIÈRE.

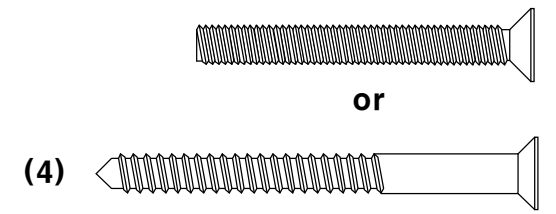

1 1/4 [57]

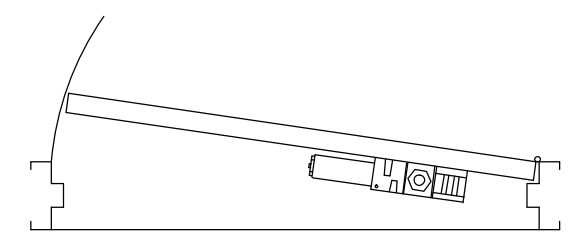

FULL SIZE TEMPLATES

120° TEMPLATE

(NHO)
REGULAR,
RÉGULIER

LEFT HAND
MANO IZQUIERDA
MAIN GAUCHE

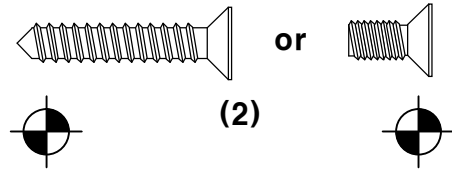

TOP EDGE OF DOOR

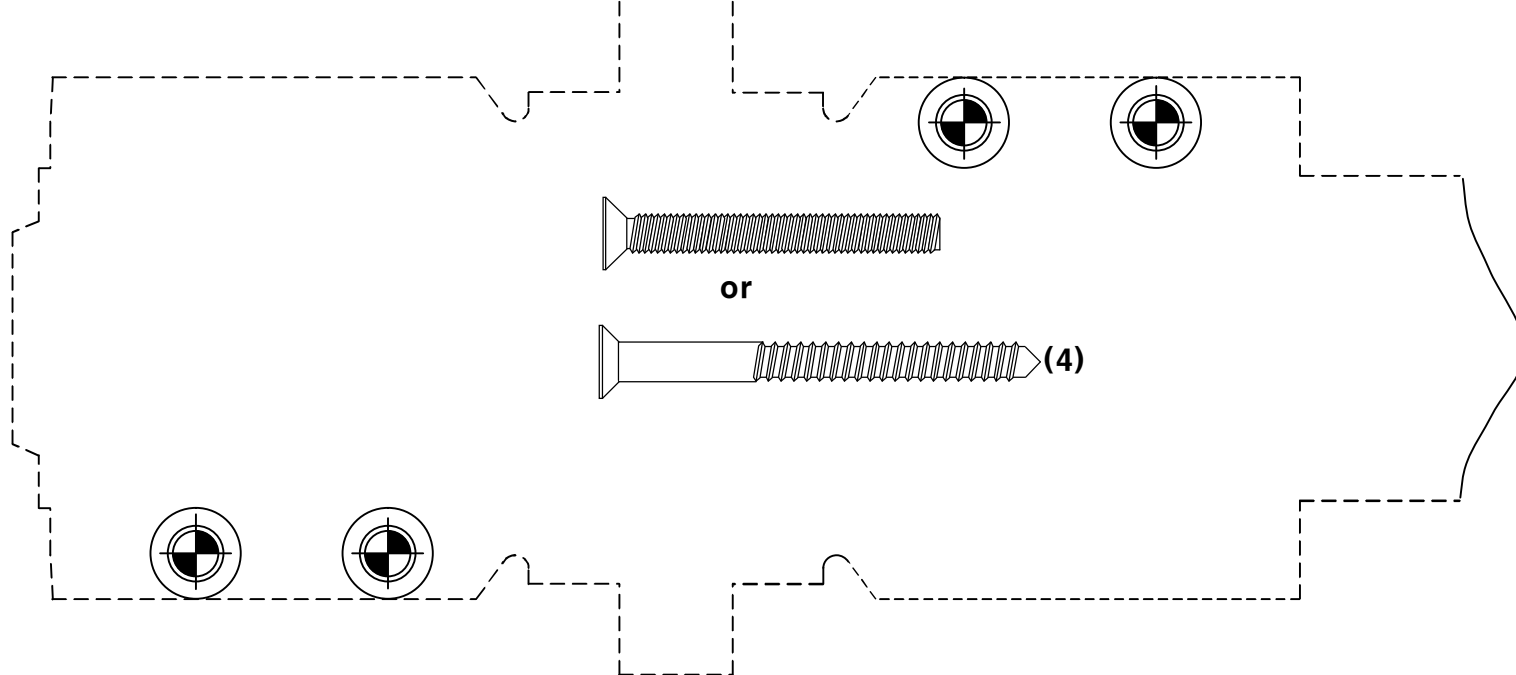

ALIGN LINE WITH BOTTOM OF FRAME FACE.
ALINEE CON LA PARTE BAJA DE LA CARA DEL MARCO.
ALIGNER CETTE LIGNE SUR LE BAS DE LA FACE DU CADRE.

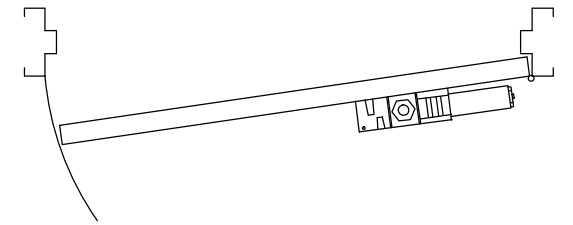

ALIGN WITH CENTER LINE OF HINGE.
ALINEE CON EL EJE DE LA BISAGRA.
ALIGNER SUR LE CENTRE DU PIVOT DE LA CHARNIÈRE.

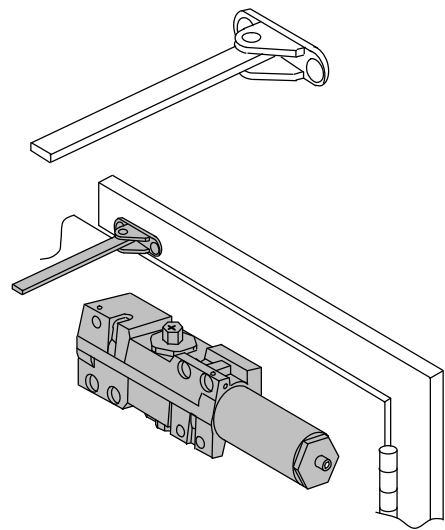

METAL . 7/32" & 1/4-20 TAP, FOR WOOD 5/32". (FOR SEX NUTS USE 3/8")
CANILLA DE METAL 7/32" & 1/4-20, PARA MADERA 5/32". (PARA USO DE TUERCAS DE 3/8")
MÉTAL 7/32" & 1/4-20, bois 5/32". (ÉCROUS M-F, PERCER 3/8")

TEAR ALONG DOTTED LINE

TIRE DE LA LINEA PUNTEADA

DÉTACHER SUR LA LIGNE POINTILLÉE

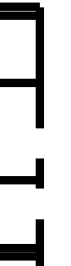

**LEFT HAND
MANO IZQUIERDA
MAIN GAUCHE**

120° TEMPLATE

METAL . 7/32" & 1/4-20 TAP, FOR WOOD 5/32". (FOR SEX NUTS USE 3/8")
 CANILLA DE METAL 7/32" & 1/4-20, PARA MADERA 5/32". (PARA USO DE TUERCAS DE 3/8")
 MÉTAL 7/32" & 1/4-20, bois 5/32". (ÉCROUS M-F, PERCER 3/8")

**(NHO)
TOP JAMB
MARCO SUPERIOR,
LINTEAU SUPÉRIEUR**

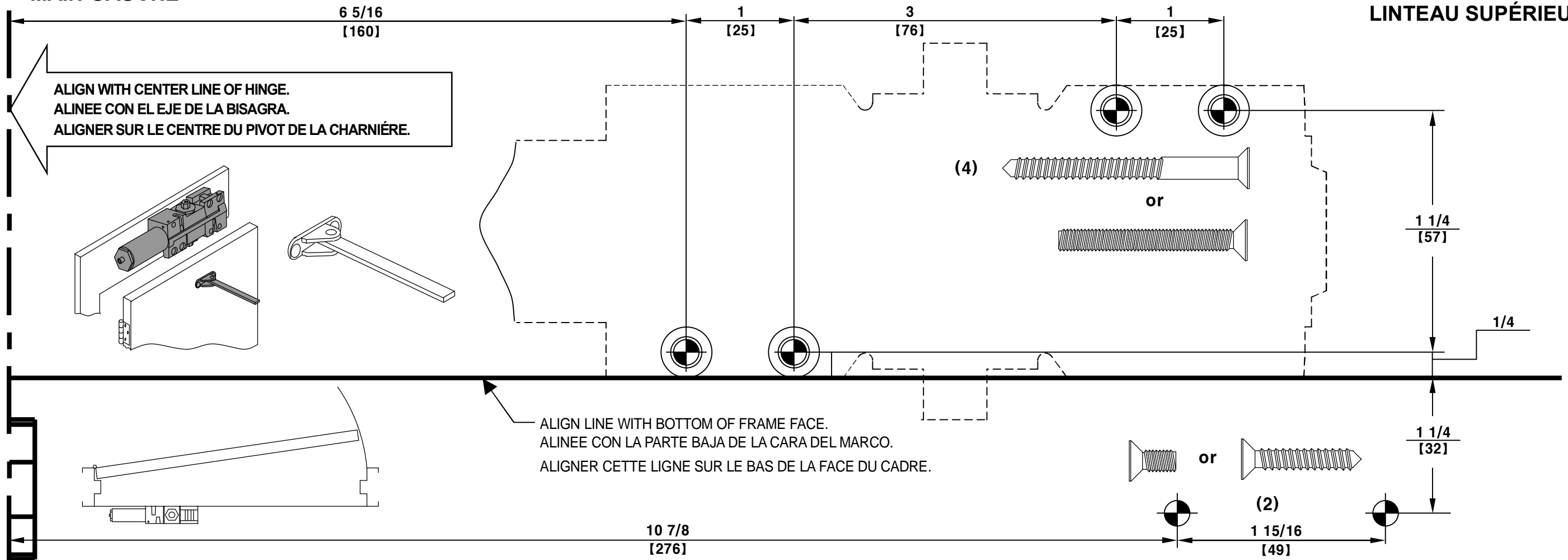



TEAR ALONG DOTTED LINE

TIRE DE LA LINEA PUNTEADA

DÉTACHER SUR LA LIGNE POINTILLÉE

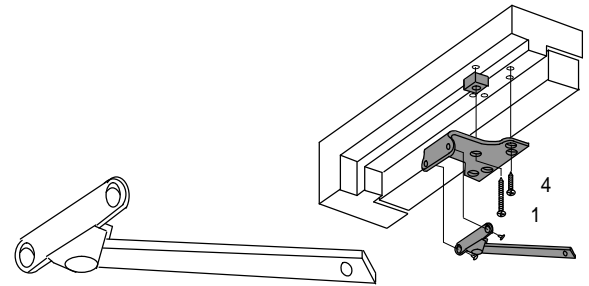
LEFT HAND
 MANO IZQUIERDA
 MAIN GAUCHE
 180° TEMPLATE

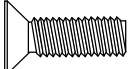
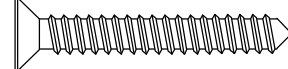
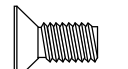

- (1)  or 
- (4)  or 

(NHO)
 TOP JAMB
 MARCO SUPERIOR,
 LINTEAU SUPÉRIEUR

FOLD AND ALIGN LINE WITH BOTTOM OF STOP.
 DOBLE Y ALINEE CON LA PARTE BAJA DEL TOPE.
 PLIER ALIGNER CETTE LIGNE SUR LE BAS DE ARRÊT.



METAL . 7/32" & 1/4-20 TAP, FOR WOOD 5/32", (FOR SEX NUTS USE 3/8")
 CANILLA DE METAL 7/32" & 1/4-20, PARA MADERA 5/32", (PARA USO DE TUERCAS DE 3/8")
 MÉTAL 7/32" & 1/4-20, bois 5/32", (ÉCROUS M-F, PERCER 3/8")

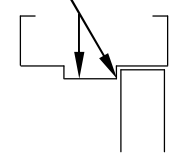

ALIGN WITH CENTER LINE OF HINGE.
 ALINEE CON EL EJE DE LA BISAGRA.
 ALIGNER SUR LE CENTRE DU PIVOT DE LA CHARNIÈRE.

