

Offset Arm for OHC Aluminum Door & Frame

Installation Instructions

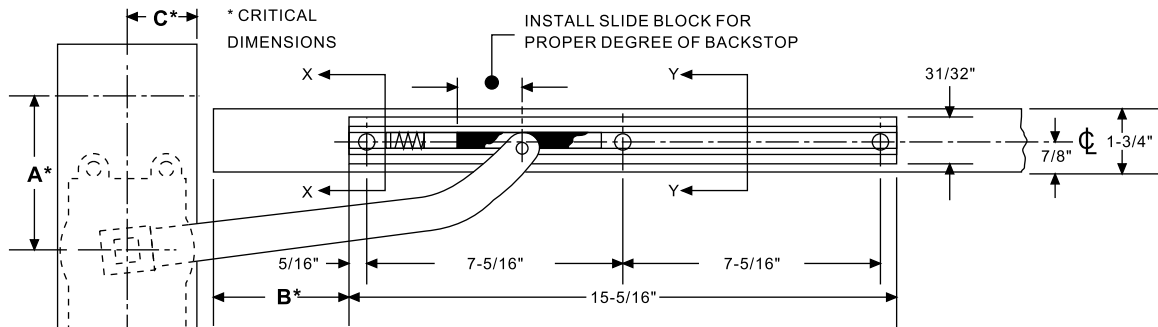

DETERMINE HOW DOOR IS HUNG AND DEGREE OF CLOSER BACKSTOP AND USE APPLICABLE CHART

HEADER PREPARATION:

1. DIMENSION 'A', face of jamb to center line of spindle must be maintained.
2. DIMENSION 'D', pivot of hinge side of header to center line of spindle must be maintained regardless of header width.
3. All spacers and/or anchors other than standard 'F' clip package by others.

DOOR PREPARATION:

1. Rout out web of top rail as shown for side channel spacers as required to be furnished by door manufacturer.
2. Rout inside face of top rail as shown for arm.
3. Offset pivots or butts by others.

INSTALLATION:

1. Install closer in prepared header.
2. Install slide channel in top rail.
3. Insert slide in slide channel with end marked 90° toward hinge edge of door if 90° backstop closer is used or with end marked 105° toward hinge edge of door if 105° backstop closer is used.
4. Place arm on spindle and tighten 1/4-20 socket head screw securely. Rotate arm from center as if door were open. Place hole in arm over pin in the slide and secure with the 'C' clip.

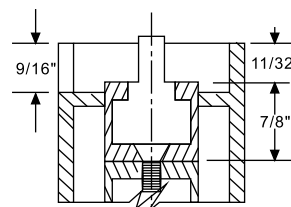
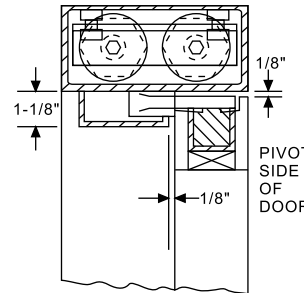
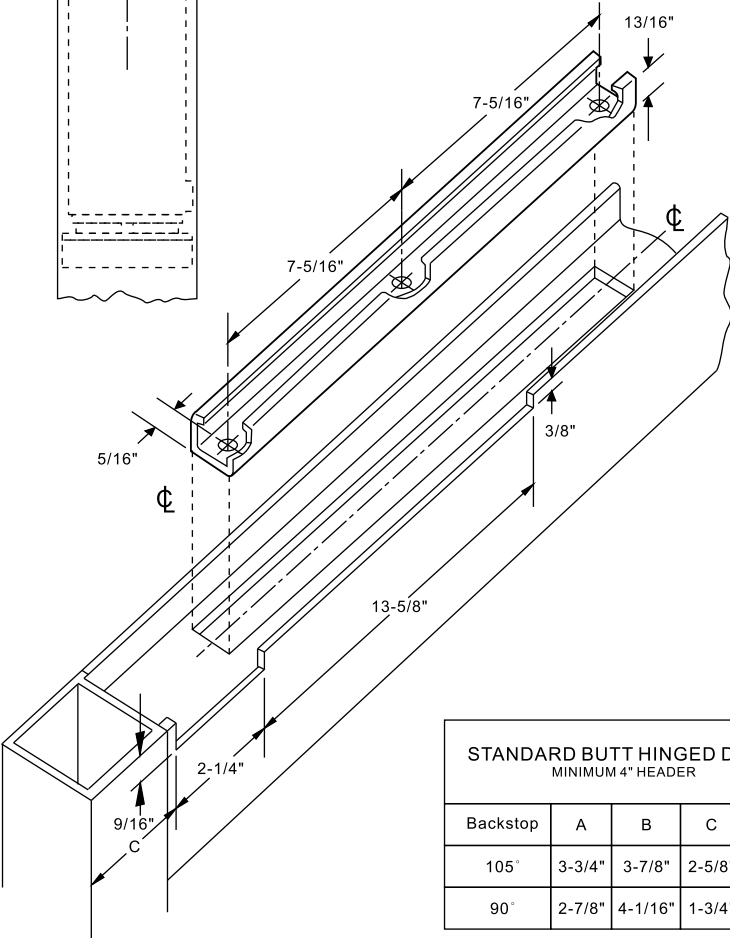

**SECTION XX
ALUMINUM FRAME DOOR**

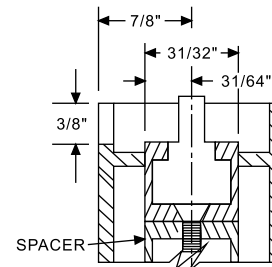

SECTION YY

STANDARD BUTT HINGED DOOR MINIMUM 4" HEADER				
Backstop	A	B	C	D
105°	3-3/4"	3-7/8"	2-5/8"	2"
90°	2-7/8"	4-1/16"	1-3/4"	2"

3/4" OFFSET PIVOTED DOOR FLUSH DOOR MINIMUM 4" HEADER				
Backstop	A	B	C	D
105°	4-1/2"	4-11/16"	3-3/2"	2"
90°	3-3/4"	4-15/16"	2-3/8"	2"

5/8" OFFSET PIVOTED DOOR 1/8" RECESSED DOOR MINIMUM 4" HEADER				
Backstop	A	B	C	D
105°	4-1/2"	4-11/16"	3-3/8"	2-1/8"
90°	3-3/4"	4-15/16"	2-3/8"	2-1/8"